

ARLISS-M  
Design Guide  
Version 1.1

|

# ARLISS-M Design Guide

## How to use this publication:

This document presents requirements, recommendations, and general information regarding the design of ARLISS-M rockets. Specific design requirements will be written in *italics* and contain the word *must*. Recommendations will also be written in *italics* and will contain the word *should*. It is assumed that people building ARLISS-M rockets are experienced rocketeers, who have already demonstrated (or are using this project to demonstrate) HPR Level 3 Certification competency. Given this audience, requirements set forth by this document will be the minimum set that enables ARLISS flyers to support our commitments to the students and universities.

## Change History:

### Version 1.1:

This version contains the updates decided from the 6/6/08 ARLISS meeting at SJSU.

- All new rockets must be reviewed by a member of the ARLISS Technical Advisory Panel (TAP) before it is allowed to fly a student payload.
- At least one flight computer must record flight data. The flight data must be sent to the ARLISS organization for distribution.
- Payload carriers will be supplied by the ARLISS organization. The size has been standardized. The new payload carrier will contain a cap that will replace the nosecone drag disk.

### Version 1.0:

Major additions were made in this version.

- Initial publication.

# ARLISS-M Design Guide

<b>1</b>	<b>OVERVIEW OF THE ARLISS PROGRAM.....</b>	<b>4</b>
1.1	STUDENT GOALS.....	4
1.2	FLYERS GOALS .....	5
<b>2</b>	<b>THE ARLISS-M REFERENCE DESIGN.....</b>	<b>6</b>
2.1	THE ARLISS-M FLIGHT PROFILE.....	6
2.2	NOSECONE SECTION.....	6
2.2.1	<i>Preventing premature separation.....</i>	7
2.2.2	<i>Parachute sizing.....</i>	8
2.2.3	<i>Optional nosecone payload compartment.....</i>	8
2.2.4	<i>Nosecone deployment issues.....</i>	9
2.3	PAYLOAD SECTION.....	9
2.3.1	<i>The standard payload carriers.....</i>	11
2.3.2	<i>The avionics unit.....</i>	13
2.3.3	<i>The parachute compartment.....</i>	15
2.3.4	<i>Preventing premature separation.....</i>	16
2.4	BOOSTER SECTION .....	17
2.4.1	<i>Securing the M1419W motor.....</i>	18
2.4.2	<i>Parachute attachment.....</i>	19
2.4.3	<i>Fins.....</i>	19
2.4.4	<i>The forward coupler and bulkhead assembly.....</i>	19
2.5	ROCKET STABILITY .....	19
	<b>APPENDIX A. PRESSURE EQUALIZATION PORT SIZE CALCULATIONS.....</b>	<b>21</b>
	<b>APPENDIX B. SHEAR PIN/SCREW CALCULATIONS.....</b>	<b>22</b>
	<b>APPENDIX C. EXPECTED BATTERY LIFE CALCULATIONS.....</b>	<b>24</b>
	<b>APPENDIX D. REFERENCE DESIGN DRAWINGS.....</b>	<b>27</b>

# Super-ARLISS Project

## 1 Overview of the ARLISS program

ARLISS - A Rocket Launch for International Student Satellites is a program designed to provide an educational experience to students in the design, flight and data analysis of a space experiment. The ARLISS program is a collaborative effort between students and faculty at Stanford University Space Systems Development Program, other educational institutions, and AEROPAC, to build, launch, test and recover prototype satellites. This program is intended to prepare students for an exciting, technical challenge that may lead to launching space experiments into low earth orbits and beyond. Students build small "satellites" that are lifted to 10,000 - 12,000 feet AGL and then deployed for descent on parachute for space demonstration experiments.

Two classes of student satellites are currently supported, CanSat class and Open class satellites.

- CanSat satellites are the size and weight of standard US 12 oz. soda cans. (Dia. 2.600 +/- 0.005 inch, mass of ~350 grams). The size of a CanSat in its launch configuration (packed inside a rocket's payload carrier) must not exceed the size of a standard soda can. After deployment, the CanSat's may deploy antennas, experiments or other devices and exceed the size limit. The ARLISS-M CanSat payload carrier is designed to carry three CanSats. Space is also provided for a 36-inch parachute for each CanSat.
- Open class satellites may be up to 5.770 inches in diameter, 10-inches deep and a weight of up to 4 pounds. The ARLISS-M Open class payload carrier is designed to carry one satellite. The satellite's recovery device (e.g. parachute) must also be included within these limits.

AEROPAC provides launch vehicles, capable of lofting and safely deploying these satellites within the above specified altitude range giving them a "hang time" in the air of about 15 minutes for experiments, simulating a horizon-to-horizon low orbit pass.

Since students depend upon these flight vehicles to safely and reliably deploy their satellites, ARLISS rockets are held to a higher standard than typical high power rockets. An ARLISS-M rocket built to this reference specification by a certified Level 3 HPR flyer need not be flight tested before it is permitted to carry a student payload. *Any ARLISS rocket that significantly deviates from the current reference design or built as a Level 3 HPR certification project must be flight tested before it is permitted to carry a student payload.*

### 1.1 Student Goals

The goals of the student's flights vary. Some student satellites make atmospheric measurements. Others perform experiments in GPS tracking, video communications, or other forms of telemetry.

One of the most popular projects is entering an Open class satellite in the international "come back" competition. In this event, student satellites attempt to return to a designated

# ARLISS-M Design Guide

ground target zone. The satellites may guide their descent to land on the target; or they may land and then propel themselves to the target; or they may land and call an autonomous rover to pick it up and deliver it to the target.

## **1.2 Flyers Goals**

- **The flyer's primary goal is to deploy the student payloads safely and dependably within the specified altitude range.**

The requirements set forth by this document are in support of the above goal. Student payloads are matched to ARLISS rockets in a random manner and it is important that no payload has an advantage or disadvantage due to the ARLISS rocket to which it is matched.

An ARLISS rocket may make five to seven flights during an ARLISS launch event. To accomplish this, the ARLISS rocket reference design has evolved to be very rugged and to use interchangeable field replaceable parts in critical areas. Secondary goals of the flyer should be:

- Make the rocket durable and able to survive dozens of flights.
- Components that are subject to damage during normal flight should be made to be field repairable or replaceable.
- Use standard interchangeable parts. The use of standard interchangeable parts helps lower the cost of building and flying ARLISS rockets. Their use also facilitates the availability of replacement parts at the launch event. It is not uncommon for a flyer to borrow or purchase a spare part from another flyer to keep their ARLISS flying during an event.
- Design the rocket to minimize launch preparation and turnaround time. Launches are often plagued by poor weather conditions. When good launch windows occur, the rocket needs to be quickly prepared for launch to take advantage of it.

Provided that they do not diminish the support of the primary goal, the flyer may also establish his/her personal goals. For example, some flyers have chosen to add a video camera to record the flight and satellite deployment.

## 2 The ARLISS-M Reference Design

### 2.1 The ARLISS-M flight profile

*All ARLISS-M rockets must execute the below flight profile.*

*At launch a 98 mm M1419W motor propels the rocket to 11,000 +/- 1000 feet. At apogee, the payload section deploys a parachute that will limit its descent to less than 40 feet per second. The parachute inflates and the payload section orients itself so that the student satellite(s) will be deployed on a downward trajectory. The path of this trajectory must be clear of ARLISS rocket components that could interfere with the deployment of the satellite(s). The payload carrier is ejected and the student satellite(s) deployed. All sections of the ARLISS rocket drift back to earth at a safe descent rates.*

To achieve the above flight profile, the current reference design is constructed of three sections. (See section Appendix D for detailed drawings.)

- Nosecone section
- Payload section
- Booster section

The motor carries the rocket to altitude. At apogee, the booster and payload sections separate. Each section has its own parachute. Six seconds elapse permitting the parachutes to inflate, the two sections drift apart, and the payload section to orient itself properly. At six seconds after the apogee event, the nosecone section and payload carrier are ejected. The nosecone section falls freely away and deploys its own small parachute. The travel of payload carrier is arrested by tether. The sudden stop of the payload carrier results in the deployment of the student satellite(s). The booster section, payload section, and nosecone section drift to earth on their parachutes.

### 2.2 Nosecone section

The nosecone section consist of:

- Nosecone
- Nosecone bulkhead
- Nosecone parachute
- Parachute tether
- Drag disk
- An optional balancing or auxiliary payload chamber

The typical ARLISS nosecone is hollow. The hollow space at the base of the nosecone is used to house its parachute and tether. A bulkhead is secured into the nosecone to act as a ceiling to this parachute compartment. The bulkhead prevents the parachute from being pushed too far into the nosecone and acts as the attachment point for the parachute tether. The other end of the tether is attached to the drag disk. The parachute is attached to the tether approximately 1/3<sup>rd</sup> of the way between the drag disk and the nosecone, so that the nosecone and drag disk will not impact each other during descent. The drag disk is the payload carrier lid and is supplied by the ARLISS organization as part of the carrier. When the payload carrier and nosecone are ejected from the payload body tube, the nose

# ARLISS-M Design Guide

cone's momentum will pull the drag disk lid off of the payload carrier, deploying the payload. The drag disk will also catch the air stream moving around the nosecone and pull out the nosecone parachute.

*When the student payload is delivered to the flyer, the flyer must attach the rocket's nosecone tether to the eye-bolt in the drag disk lid of the supplied payload carrier.*

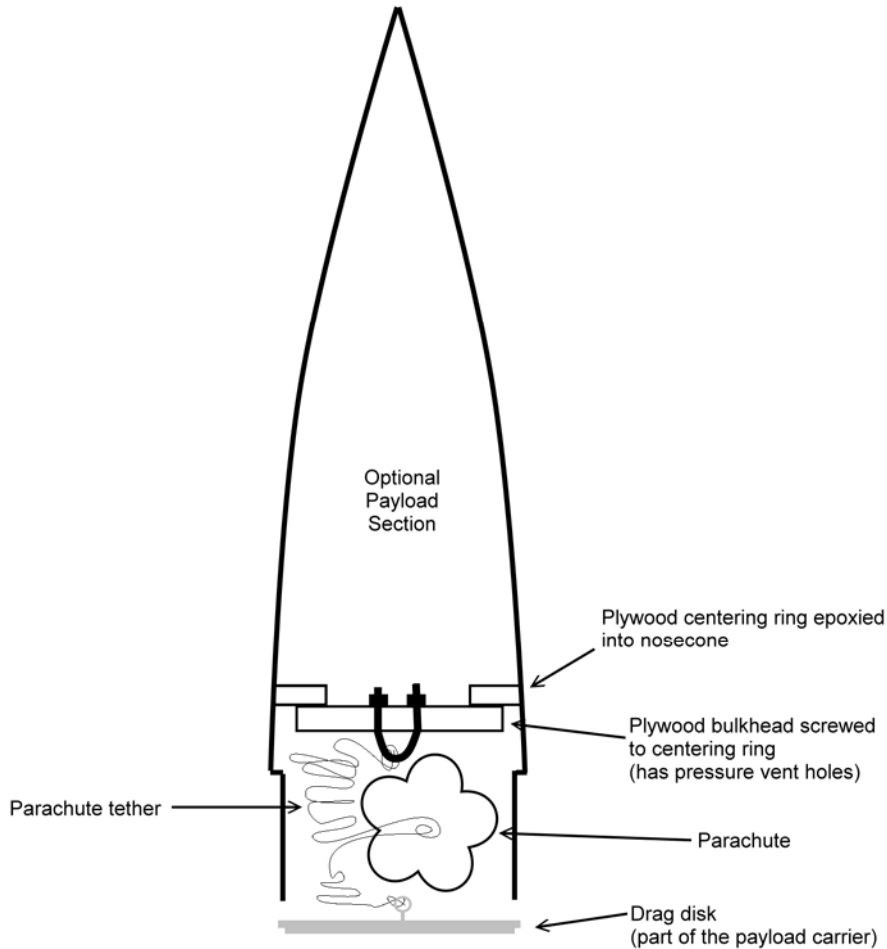

Nosecone Section

## 2.2.1 Preventing premature separation

In the typical ARLISS-M rocket, about 525 cubic inches of air is trapped in the top of the payload section and hollow nosecone. The altitude induced air pressure differential acting on this volume of trapped air may be sufficient to cause premature separation of the nosecone section from the payload section as the rocket nears apogee. *Premature separation of the nosecone section must be prevented. To prevent premature separation this compartment should be vented and/or the nosecone should be secured to the payload section by shear pins/screws.*

# ARLISS-M Design Guide

*Vent hole(s) should be large enough to limit the internal to external pressure differential, but small enough such that ejection gas pressure loss is not excessive.* It is common to drill a vent hole(s) in the payload section body tube just above the top of the payload carrier and below the collar of the nosecone. Vent holes may also need to be drilled internally so that air can vent through the drag disk and nosecone bulkhead. (See Appendix A for a method of vent port size calculations.)

Use of shear pins vary from two rods of 1/16<sup>th</sup> inch polystyrene to four #4 nylon screws. Using too many or too thick shear pins will result in excessive ejection G-forces being exerted on the satellites. Vent hole(s) have the opposite effect on G-forces. Ejection gas escaping through vent hole(s) bleeds off energy that would normally be transferred to the satellites. Note also that once the ejection device is triggered and the payload carrier moves slightly forward, the vent hole(s) will be blocked until the carrier is nearly free of the body tube. (See Appendix B for a method of calculating shear pin sizes.)

The specific choice of vent holes and shear pins will depend on the air volume inside your rocket and the tightness of the nosecone to body tube fit. One combination that is commonly used is one 1/8-inch vent hole and two #2-56 nylon screws.

## **2.2.2 Parachute sizing**

The reference ARLISS rocket is designed to be recovered in three pieces. It is desirable to have all three pieces land in approximately the same location. Since there are few constraints on the nosecone parachute, we suggest that the other parachutes are sized first and then the nosecone parachute size can be selected to match the descent rates of the other rocket sections.

A common parachute size for a nosecone without the optional payload is 42 inches. Of course, the appropriate size for your rocket will depend on the style of parachute used and the mass of your nosecone section.

## **2.2.3 Optional nosecone payload compartment**

If the nosecone bulkhead is removable, then the compartment above the bulkhead can be used as an auxiliary payload compartment. Flyers often choose to mount a camera, tracking transmitter, or a GPS transmitter in this compartment. Having a tracking or GPS transmitter on the rocket can significantly improve recovery time and therefore turnaround time.

A small amount of ballast mass can also be added in this compartment to move the rocket's center of gravity forward. Usually, the mass of the student payloads are more than enough to make the rocket stable, but if the ARLISS flies without (or with a very light) payload, you may need to add ballast mass. The addition of significant ballast mass may require strengthening of the nosecone collar.

A common method of making the area above the nosecone bulkhead accessible for payload use is to epoxy a centering ring to the nosecone just above the desired location of



# ARLISS-M Design Guide

the nosecone bulkhead. Payloads can then be fastened to the top surface of the bulkhead. The bulkhead/payload assembly is then inserted into the nosecone with the payload passing through the hole in the centering ring. The bulkhead is fastened to the centering ring using machine screws and tee-nuts.

## 2.2.4 Nosecone deployment issues

- Drag disk being pushed into nosecone
- Nosecone collar damage

At the time of nosecone ejection, significant forces (gas pressure and payload carrier impact) are exerted against the drag disk and nosecone collar. If ejection forces push the drag disk into the nosecone, the nosecone parachute will not deploy. The junction between the nosecone collar (the part of the nosecone that slides inside the payload section body tube) and the rest of the nosecone seems to be a weak point that is susceptible to cracking and fracture caused by ejection forces.

The drag disk can be prevented from being pushed into the nosecone by building it from a material that will resist distortion and maximizing the size difference between the diameter of the drag disk and the inner diameter of the nosecone collar. *The drag disk diameter should be the largest diameter that will easily fit into the payload section body tube.* The nosecone collar internal diameter may need to be reduced by adding a layer of reinforcement material.

If the layer of reinforcement material (discussed in the previous paragraph) is extended to cover the junction between the nosecone collar and the rest of the nosecone, it will significantly improve the strength of this weak point.

## 2.3 Payload section

The payload section of the reference design consists of:

- Payload section body tube
- Payload carrier
- Payload carrier tether
- Avionics unit
- Avionics compartment thrust ring
- Payload section parachute
- Payload section parachute tether

# ARLISS-M Design Guide

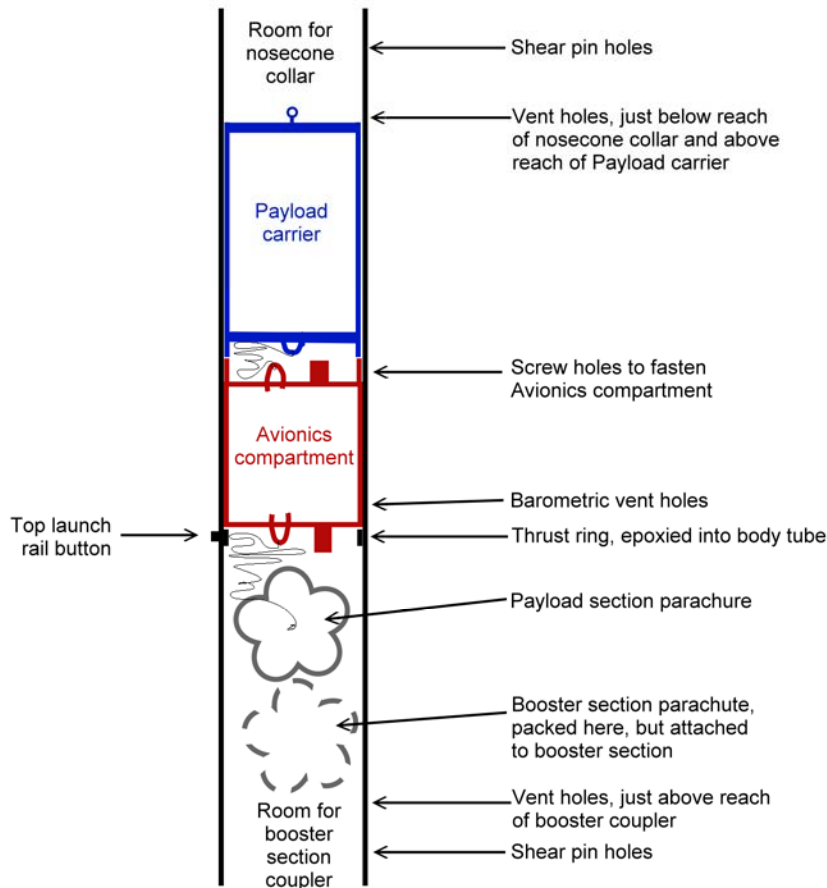

## Payload Section

The payload section is the longest section of the ARLISS rocket. Its total length is typically between 48 and 54 inches. The factors that add up to this length are (from top to bottom):

- 5.5 to 6 inches length to accommodate the nosecone collar
- 12.1 inches length to accommodate the standard payload carrier
- 1 to 4 inches length to accommodate the payload tether and payload carrier ejection mechanism
- 6 to 12 inches length to accommodate the avionics compartment
- 12 to 22 inches length to accommodate the parachute ejection mechanism, the payload section parachute and tether, and the booster section parachute and tether
- 6 inches length to accommodate the booster section's forward coupler

The thrust force of the motor is transferred from the booster section to the payload section's body tube. The payload carrier (including satellite(s)) and avionics unit are significant mass items that need to be accelerated by this force. To accomplish this, a ring of coupler tubing (the avionics compartment thrust ring) is epoxied to the body tube just below the point where the avionics compartment is to reside. The avionics compartment is seated on this ring and the payload carrier is seated on top of the avionics

## ARLISS-M Design Guide

compartment. Motor thrust is transferred to the avionics unit and payload carrier through this ring. The avionics compartment thrust ring is the only component that is permanently attached to the payload section body tube. All other components are removable. The reinforcement offered by the thrust ring provides a good mount point for the upper launch rail button.

### 2.3.1 The standard payload carriers

The purpose of the payload carrier is to hold the student satellite(s) during upward flight and deploy the satellite(s) safely per the above flight profile. The dimensions and mass of student satellites have been standardized. This permits the design of standard and therefore interchangeable payload carriers. (See Appendix D for a detailed drawing of the external surfaces of the carrier.)

The nosecone parachute tether attaches to the eye-bolt on the top lid of the carrier (also called the drag disk). The payload carrier tether attaches to the bottom of the payload carrier and to the top of the avionics compartment. During the payload deployment event, the payload carrier and nosecone are ejected out of the body tube. They will travel the length of both tethers, and then when the tethers becomes taut, the lid will be pulled off the payload carrier and the satellite(s) are deployed out of the carrier by their inertia. The elasticity of the tether may then accelerate the payload carrier back toward the payload section body. *The length of the tether should be sufficient to allow for gravity and drag to attenuate the elastic force so that the carrier does not impact the payload section body. A minimum length of 10 feet of .5" nylon webbing is recommended.* The carrier lid will return to ground with the nosecone. The rest of the payload carrier will return to ground with the payload section of the rocket.

Payload carriers are supplied to student teams from a common pool. A team will pack its satellite(s) into the carrier, and then contact an ARLISS flight coordinator to be assigned to an ARLISS rocket. The flier will attach the payload and nosecone tethers to the carrier and load it into the rocket. Carriers may become bent, chipped, or swollen with use. *The flier must check the fit of the carrier to the rocket. The carrier must fit inside the payload section body tube such that it will be reliably ejected without subjecting the payload to excessive G-forces.*

#### 2.3.1.1 Open class payload carrier design

Eighty percent of student satellites are built to the Open class specification. Since ARLISS-K rockets can carry CanSats, but not Open class satellites, ARLISS-K rockets are given priority for CanSat launches. This means that ARLISS-M rockets will predominantly fly Open class satellite missions.

*The satellite compartment of the Open class payload carrier must accommodate a 10-inch long, 5.770-inch diameter satellite.*

# ARLISS-M Design Guide

## 2.3.1.2 Divided payload carrier for CanSats

*The ARLISS-M CanSat class carrier must support the deployment of three CanSat satellites per launch. The dimensions of the CanSat class carrier are identical to the Open class carrier with the addition of a 1/2-inch diameter central rod and three walls that divide the Open class satellite compartment into three equal pie wedge shaped CanSat compartments.*

## 2.3.1.3 Payload carrier deployment issues

- G forces
- Black Powder vs. CO<sub>2</sub> ejection
- Carrier bounce-back
- Carrier damage

Student satellites are expected to tolerate the normal G-forces of lift-off acceleration and deployment. However, *care must be taken so that student satellites are not subjected to excessive G-forces.*

When black powder is used for payload ejection, G-forces can easily become excessive. *The size of a black powder charge must be limited to the minimum that will reliably deploy the payload. This charge should be limited to 2-grams or less.* The advantages of black powder ejection are simplicity of design and compactness of the required hardware.

CO<sub>2</sub> ejection systems provide a more gradual buildup of pressure and therefore subject the payload to less ejection G-force. They also have the advantage of being non-corrosive and the cold expanding gas is generally less damaging than the heat and molten residue produced by black powder. It is typical for an ARLISS-M rocket to use a 24-gram CO<sub>2</sub> cartridge for payload ejection. See <http://www.rouse-tech.com/> for more information on CO<sub>2</sub> ejection systems.

*The amount of free travel the payload carrier has before it contacts the nosecone collar must be minimized. When the amount of free travel is too great, the payload carrier has been shown to impact the nosecone collar (actually the nosecone drag disk), transfer nearly all its energy to the nosecone, eject the nosecone with good force, but not retain sufficient force to exit from the payload section body tube. This carrier bounce-back phenomena also occurs when too small of an ejection charge is used. Typically there is only about 1/8-inch of free travel for the payload carrier. ARLISS flyers must ground test their payload ejection systems before flying a student payload.*

Payload carriers are commonly made from phenolic tubing, which is very susceptible to impact damage. Fiberglass carriers are also used, but they typically weigh 50% more and are twice the cost of the phenolic carriers. *When a flyer attends an ARLISS event, the flyer should bring at least two Open class carriers and one carrier capable of holding CanSat class satellites.* If removable dividers are used, then a total of only two carriers are needed.

# ARLISS-M Design Guide

## 2.3.2 The avionics unit

The avionics unit consists of:

- Avionics compartment (a hollow cylinder with top and bottom bulkheads)
- Payload and Parachute ejection mechanisms
- Redundant flight computers
- Batteries and other support electronics
- Optional tracking or GPS transmitter

### 2.3.2.1 The avionics compartment

The avionics compartment contains and protects the rocket's flight electronics system. The motor thrust is transferred from the avionics thrust ring to the avionics compartment and through the wall of the compartment to the payload carrier. *The compartment must be strong enough to accelerate its internal components and everything that is seated on top of it.* Given the ARLISS-M reference design, this includes the payload carrier and payload.

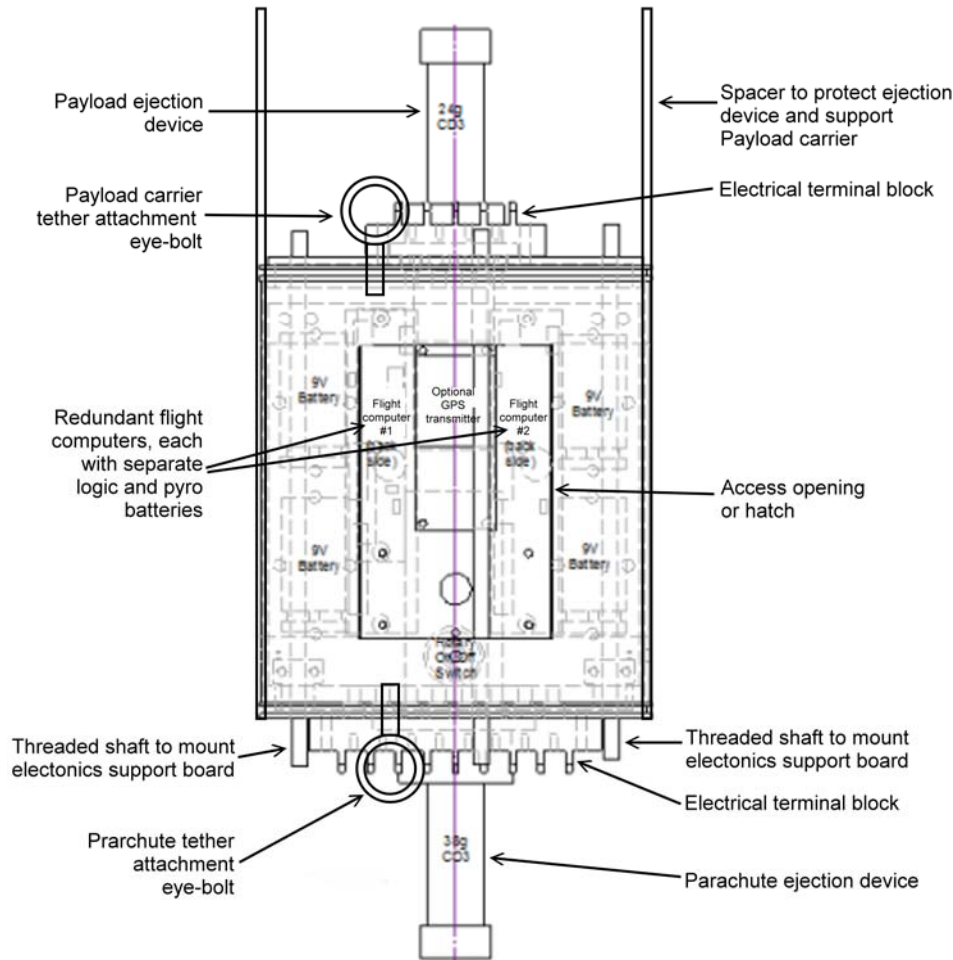

Avionics Compartment

# ARLISS-M Design Guide

The payload ejection mechanism is mounted on top of the compartment's top bulkhead. Its electrical leads pass through the bulkhead and connect to the flight electronics. The payload carrier tether's eyebolt (or U-bolt) is anchored in this bulkhead.

The parachute ejection mechanism is mounted on the bottom of the bottom compartment bulkhead. Its electrical leads pass through the bulkhead and connect to the flight electronics. The payload section's parachute tether's eyebolt (or U-bolt) is anchored in this bulkhead.

*The compartment must also be strong enough to tolerate the deployment shock of the parachute and the payload carrier. The avionics compartment must be secured to the payload section body tube so it is not moved upward when the parachute ejection charge is triggered. Upward movement of the avionics compartment will cause premature separation of the nosecone.*

Flight electronics are very sensitive to corrosive gasses. *The compartment must protect the flight electronics from the ejection gas pressure and corrosiveness.* Erroneous barometric measurements due to gas leakage could cause flight computers to prematurely trigger events. *Bulkhead holes should be sealed with a compound like RTV. Care should be taken to prevent ejection gas from passing around compartment bulkheads and entering the compartment through access holes in the wall of the compartment.* Some flyers use O-rings the top and bottom of the avionics compartment to prevent gasses from passing between the body tube and the wall of the avionics compartment.

## 2.3.2.2 The flight electronics

*The rocket's flight electronics must reliably support the ARLISS Flight Profile. To make the electronics function dependably, there must be no single point of failure in the flight electronics system. This rule applies not only hardware, but also architecture and software implementation. This means that not only must an ARLISS-M have two flight computers, but also the flight computers must be different models. Ideally, different manufacturers should make the flight computers. Both flight computers must be able to trigger the deployment of booster and payload section parachutes (apogee event). It is recommended, but not required that both flight computers be able to trigger the payload deployment event (apogee+6 seconds).*

Other rules applying to the flight electronics are:

- *The flight electronics that is connected to the ejection mechanisms must be turned off or disabled until the rocket is on the launch pad. However, it must be turned-on and active before the rocket motor's igniter leads are connected.*
- *At least one of the flight computers must be capable of recording acceleration and pressure at regular intervals (typically every second) during the flight. The raw flight data must be sent to the ARLISS coordinator so that it can be analyzed and published.*
- *Flight computers should detect apogee from accelerometer measurements.*
- *The avionics compartment should be vented properly to the outside so that the flight computers can make accurate barometric altitude measurements. This*

# ARLISS-M Design Guide

*recommendation becomes a requirement if either flight computer determines apogee from barometric measurements.*

- *The flyer should know the expected battery life for the flight electronics and batteries being used. If not, the batteries must be recharged or replaced after every flight. (See Appendix C for an explanation of how to calculate expected battery life.)*

*When configuring the flight computers, "inertial apogee" detection should be used to fire the parachute ejection charge; and "inertial apogee + 6 seconds" should be used to fire the payload ejection charge. Beware, many flight computers do not the 6-second delay.*

## **2.3.3 The parachute compartment**

The parachute compartment is the name for the lower part of the payload section, located below the avionics unit. Both the payload section's parachute and the booster section's parachute are packed into and deployed from this compartment. *The firing of the parachute ejection mechanism must result in the separation of the booster section from the payload section and the reliable deployment of both parachutes.*

### **2.3.3.1 Parachute ejection issues**

- Deploying two parachutes from one *compartment*
- Black Powder vs. CO<sub>2</sub> ejection

There are issues in deploying two parachutes from one compartment. *Care must be taken that the two parachutes don't tangle during deployment.* Some flyers use a parachute bag on one or both parachutes to prevent tangling. Others flyers just dress the shrouds and tethers neatly using thin rubber bands.

A larger ejection charge may also be needed to deploy two parachutes. When deploying only one parachute, if the parachute is mostly pushed out of the rocket tube, the exposed portion of the parachute may catch the air stream and pull itself the rest of the way out. When deploying two parachutes, the same percentage amount of travel may result in completely expelling one parachute and leaving only a small and insufficient part of the second parachute exposed. Some flyers just use an abundance of black powder to make sure that both parachutes are ejected. It is a simple, but a brute force way of dealing with the issue. Some flyers have installed a piston to push the parachutes out. The disadvantage of the piston is the extra mass and body tube length needed to support it. Other flyers reverse the packing of the parachutes, so that the booster parachute resides above the payload parachute. When packed this way, the separation momentum of the booster section will help pull both parachutes out of the parachute compartment. The disadvantage of this packing is a higher risk of entanglement. An improvement on the above technique is to place the booster section's parachute in a deployment bag and attach the bag to the payload parachute tether. This technique permits one parachute to help pull out the other, and reduces the probability of entanglement by slightly delaying the inflation of the booster section parachute.

# ARLISS-M Design Guide

The best practice for deployment of both parachutes parachute is still being actively debated. You are free to choose the method, or combination of methods, with which you are most comfortable. *The parachute deployment method that you chose must be ground tested with your rocket.*

Rather than using black powder ejection of the parachutes you may choose to use a CO<sub>2</sub> based ejection mechanism. The advantages and disadvantages are same as the ones discussed above (in section 2.3.1.3). It is typical for an ARLISS-M rocket to use a 38-gram CO<sub>2</sub> cartridge for parachute ejection. However, using this cartridge alone has been shown to be unreliable in deploying two parachutes. *CO<sub>2</sub> ejection must be combined with some other mechanism to assist it in deploying the parachutes. It is strongly recommended that CO<sub>2</sub> ejection be combined with at least a piston.*

## 2.3.3.2 Parachute sizing

*The parachute should be sized to achieve the desired descent rate for the section.* The Internet provides several resources for sizing parachutes. A very good web site is <http://www.b2rocketry.com/news.htm>. A very good article that presents descent data for many of the most popular parachutes is "The Great Parachute Driftoff" by Bruce Kirby, published in the December 1998 High Power Rocketry magazine. A web copy can be viewed at <http://www.b2rocketry.com/PDF%20files/Kilby.pdf>.

Many flyers choose their descent rates (and therefore parachute sizes) based on the weather conditions. For example, if winds are very calm a 10-ft/second descent rate might be desired. For a 12-pound rocket section, a 134-inch (R12C) parachute achieves that rate.

Under windier conditions, a 22-ft/second descent rate might be preferred. For a 12-pound rocket section, a 118-inch (R9C) parachute achieves that rate. The booster section, with its propellant expended, is about six pounds heavier. Its descent rate can be made to match the payload section by using one size larger parachute. For an 18-pound rocket section, a 134-inch (R12C) parachute descends at about 22-ft/second. A 2.4-pound nosecone section can be made to descend at about 22-ft/second by using a 42-inch (R3C) parachute.

## 2.3.4 Preventing premature separation

In the typical ARLISS-M rocket, the payload section parachute compartment volume is about 520 cubic inches. The potential trapped air volume is larger if the booster section vents into the payload section. The altitude induced air pressure differential acting on this volume of trapped air may be sufficient to cause premature separation of booster section from the payload section as the rocket nears apogee. *Premature separation of the booster section must be prevented. To prevent premature separation this compartment should be vented and/or the booster section should be secured to the payload section by shear pins/screws.*

Vent holes should be large enough to limit the internal to external pressure differential, but small enough such that ejection gas pressure loss is not excessive. *Vent holes should*



# ARLISS-M Design Guide

*not be placed in the very bottom of the payload section body tube where the booster's forward coupler could block them.* Some flyers use multiple vent holes as a precaution of the parachute cloth acting as a blockage. (See Appendix A for a method of vent port size calculations.)

Shear pins/screws are also used to prevent premature separation. Their use is discussed in section 2.2.1, and Appendix B.

The specific choice of vent holes and shear pins/screws will depend on the air volume inside your rocket and the tightness of the booster coupler to body tube fit. One combination that is commonly used is two 3/32-inch vent holes and two #2-56 nylon screws.

## **2.4 Booster section**

The booster section consists of:

- Booster section body tube
- Motor mount assembly
- Fins
- Forward coupler and bulkhead assembly
- Booster parachute and tether

The M1419W motor is used to power the ARLISS-M rocket. The typical M1419W motor generates a maximum thrust of about 375 pounds. *The booster section's thrust transfer path, from the forward motor closure to the top of the booster body tube must be built to handle the stress of this force.* Based on the typical ratios of rocket section masses, about 50% of this thrust (~180 pounds) needs to be transferred from the booster section to the payload section.

# ARLISS-M Design Guide

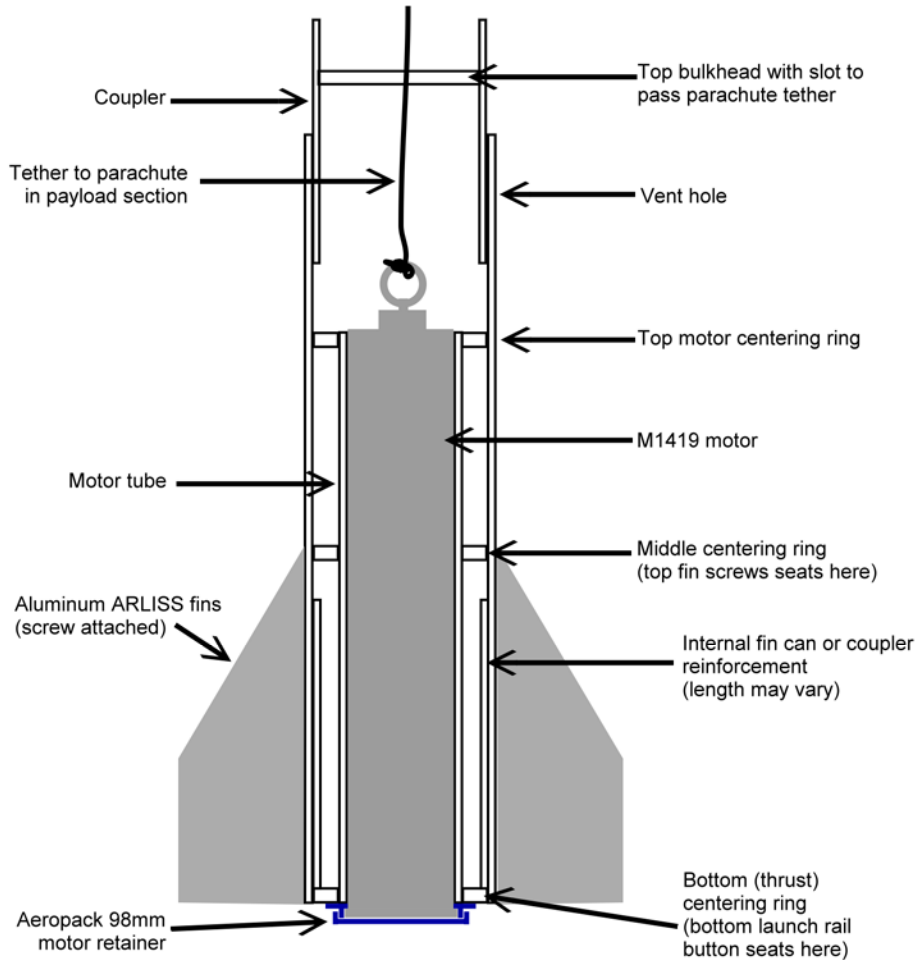

## Booster Section

The thrust path in the booster section of the ARLISS-M reference design is:

1. Motor forward closure in tension to...
2. Motor case walls in tension to...
3. Motor aft closure in compression through Aeropack motor retainer to...
4. Booster section's aft centering ring in shear to...
5. Booster body tube

The weak link in the above path is the thrust transfer between the aft centering ring and the body tube. Flyers use various techniques to reinforce this junction. Some use an internal aluminum structure. This structure is also used to reinforce the attachment of the fins to the body tube so it has acquired the name "fin can" or "fin frame". Other flyers reinforce this junction with a length of fiberglass coupler tubing.

### 2.4.1 Securing the M1419W motor

The motor aligned and horizontally secured by centering rings. In the reference design, only the aft centering ring is in the thrust transfer path. The motor is vertically secured by the aft centering ring and a 98 mm Aeropack retainer.

# ARLISS-M Design Guide

## 2.4.2 Parachute attachment

In the reference design, the booster's section parachute tether is attached to the forward motor closure. This method of attachment permits the reinforced thrust transfer path, discussed above, to dissipate the parachute's deployment shock. The tether runs up through a small hole in the booster's forward bulkhead to the parachute. The booster's parachute is not packed in the booster, but rather in the payload section. The booster's parachute's descent rate is typically selected to match the other rocket sections. Parachute sizing is discussed in section 2.3.3.2.

*To prevent trapped air in the booster section from venting into the payload section and causing premature separation of the sections, the booster section should be vented to the outside.*

## 2.4.3 Fins

ARLISS-M flights are sub-sonic. *An appropriate sub-sonic fin design should be used.* The frequent flights, large booster section mass, and rough playa surface takes a toll on fins. Interchangeable aluminum field replaceable fins have become very popular with flyers. Though not on the web site, they are available from [www.Rouse-Tech.com](http://www.Rouse-Tech.com). A drawing of the standard ARLISS-M fin is provided in Appendix D

## 2.4.4 The forward coupler and bulkhead assembly

The forward coupler and bulkhead assembly caps the booster section. This junction must transfer about 180 pounds of thrust vertically into the payload section. The upper part of the ARLISS-M rocket is also quite long and therefore can exert a substantial bending force at this junction. Most flyers use a fiberglass coupler (with a wall thickness of  $>0.07$  inches) that extends about one diameter (6 inches) into each body tube. It is secured to the booster section body tube. The coupler is reinforced by the booster's forward bulkhead, which is located within it.

*The bulkhead should not be located too low inside the coupler or a parachute may get pushed into the coupler and be trapped.* A small hole or slot is made in the bulkhead for the parachute tether to pass through. Tape is often used to seal the gap between the tether and the hole to prevent ejection gas from escaping the payload section's parachute compartment into the booster.

A second thickness of fiberglass coupler tube is usually epoxied into the coupler above the forward bulkhead to help secure the bulkhead. This reinforcement and the tether hole/slot in the bulkhead being located only a couple inches below the top of the coupler make the design very zipper resistant.

## 2.5 Rocket stability

Without a payload, the reference design ARLISS-M rocket is marginally stable (stable by less than one diameter). *Because of construction differences and because a student payload may be arbitrarily light, ARLISS-M rockets must be analyzed for stability.*

## ARLISS-M Design Guide

Although each ARLISS-M rocket will have some unique construction characteristics the critical statistics should not vary significantly from the below:

- 100 inches total length
- 27 lb. take-off weight not including motor and payload
- 77 inches distance from nosecone tip to center of pressure
- 73 inches distance from nosecone tip to center of gravity (motor loaded, but no payload)

# Super-ARLISS Project

## **Appendix A. Pressure equalization port size calculations**

<Not yet written. This appendix needs a volunteer who is knowledgeable about the subject and willing to share that knowledge.>

## Appendix B. Shear Pin/Screw Calculations

### Shear Strength

The important material property for a shear pin is the shear strength of the material from which the pin is made. The shear strength can be found on the web sites of the manufacturers and distributors of the material. The specified strength is for new material at 73°F. Shear strength is measured by the push or pull against the side of a fastener until the fastener breaks. If a tensile strength is specified, but a shear strength is not, the shear strength can be approximated as 2/3rds the tensile strength.

Shear strength is usually specified in pounds per square inch (psi). The number is used by multiplying it by the cross-sectional area of the pin, (or screw) measured in square inches.

The strength specifications of a material may vary between manufacturers, sometimes greatly. Polystyrene for example is available in tensile strengths from 1500 to 7000 psi. Other materials such as Nylon 6/6 has much tighter specifications, 9600 to 10500 psi. If you can't buy a "strength rated" component, you can calculate the shear strength range. We will do this in the example below.

### Material Quality

The published shear strengths only apply to the materials in the condition that they are shipped from the manufacturer. Plastics often absorb moisture, which will weaken them. Exposure to ultraviolet light and sunlight also weakens plastics.

The final product, e.g. "nylon screws", often only vaguely identifies the material from which the product is made. Generic nylon screws could be made from Nylon 6, Nylon 6/6, Nylon 6/12, or a blend of nylons and other materials. Screws purchased from the local hardware store typically do not specify the exact material from which they are made. On the other hand, when ordered from an industrial supplier like McMaster-Carr, not only is the exact material specified, but often a "strength rated" version of the component available.

### Cross-sectional Area

The cross-sectional area of a round shear pin is simple to compute.

$$\text{area} = \text{PI}() * (\text{diameter}/2)^2$$

The computation for a screw is more complicated. Because of the screw's threads, the diameter of the screw that should be used is less obvious. The narrowest cross-section of a screw, between the threads, is called the screw's "minor diameter". The cross-sectional area at this point is the "minor area". However, if the shear is forced to occur exactly orthogonal to the screw's axis due to a very close fit of the surfaces causing the shear, the shear cross-section will be forced to include part of the larger diameter of the thread. The screw's "pitch area" is a good approximation of this perfectly orthogonal shear cross-section. A good practice is to compute a range of shear forces within which the shear screw will break. Use the minor area to compute the minimum shear force needed to

# ARLISS-M Design Guide

break a shear screw. Use the pitch area to compute the maximum shear force needed to break a shear screw.

## An example using Nylon 6/6 shear screws

We want to choose the shear screws needed to resist a 5.5 psi pressure differential between internal trapped air and the air outside the rocket. This is the pressure differential that would occur if the rocket traveled to 12,000 feet without venting any trapped air. We will assume that the coupler to body tube fit exhibits friction that needs 5 pounds of force to separate.

A 5.5-psi pressure differential in a 6-inch diameter rocket results in section separation force of about 155 pounds. (force = 5.5 times the area of a 6 inch circle) Given that 5 pounds are needed to overcome the coupler friction, the shear screws need to withstand 150 pounds of force.

Our web search showed Nylon 6/6 found shear strengths ranging from 9600 to 10500 psi. We also found that McMaster-Carr stocks Nylon 6/6 screws in 2-56, 4-40, 6-32 UNC sizes; and M2 and M3 metric screw sizes.

Using online screw tables to find the pitch diameter and minor diameter for these screws, we calculate the pitch and minor areas. Finally, we compute the minimum shear strength of the screw by multiplying the minor area by the smaller material shear strength value; and compute the maximum shear strength of the screw by multiplying the pitch area by the larger material shear strength value.

Screw Size	Diameters (in)			Areas (sq in)		Shear Strength (lbs)	
	Major	Pitch	Minor	Pitch	Minor	Min	Max
<b>M2</b>	0.07874	0.06851	0.05942	0.00369	0.00277	<b>27</b>	<b>39</b>
<b>2-56</b>	0.08600	0.07440	0.06410	0.00435	0.00323	<b>31</b>	<b>46</b>
<b>4-40</b>	0.11200	0.09576	0.08130	0.00720	0.00519	<b>50</b>	<b>76</b>
<b>M3</b>	0.11811	0.10532	0.09396	0.00871	0.00693	<b>67</b>	<b>91</b>
<b>6-32</b>	0.13800	0.11770	0.09970	0.01088	0.00781	<b>75</b>	<b>114</b>

Using the "minimum shear strength" column, three 4-40 screws are adequate to withstand the pressure differential. The ejection charge would have to generate an additional 3 psi, plus replace any pressure loss due to the trapped air leaking out, to guarantee the screws would shear. To be safe, the ejection charge should be sized to produce the full 8.5 psi needed to shear the screws.

## Other Shear Pin/Screw Issues

Shear pins/screws should be equally positioned around the circumference of the rocket. Never use just one pin, because the coupler may cock and bind.

When using screws, don't tap both the body and the coupler and cause premature shearing. The slight threading mismatch will add stress to the screw. Tapping the body tube only makes removal of the sheared screw easy and does not stress the screw.

## Appendix C. Expected Battery Life Calculations

As a battery discharges, its voltage drops. When its voltage drops too low, the electronics it is powering will stop operating. This section explains how to estimate "how long a battery will be able to power you flight computer".

### Batteries Powering Flight Computer CPU & Logic

Most flight computers will operate until the voltage of their CPU battery drops below 80% of the rated voltage. For a 9-volt system, this means the computer will operate down to about 7 volts. Some electronic technologies can operate down to 50% or less of their rated voltage. Read your flight computer's specifications. If the specification states a minimum supply voltage, then use that number as the limit. (If it's not in the specification, flight computer manufacturers will likely respond to an e-mail asking this question.) Otherwise, use the 80% value for the limit. (G-Wiz states that their LCX and MC2 computers will operate reliably down to between 6.5 and 7 volts.)

The below chart is extracted from the Duracell MN1604 Alkaline battery datasheet (Duracell.com web site)

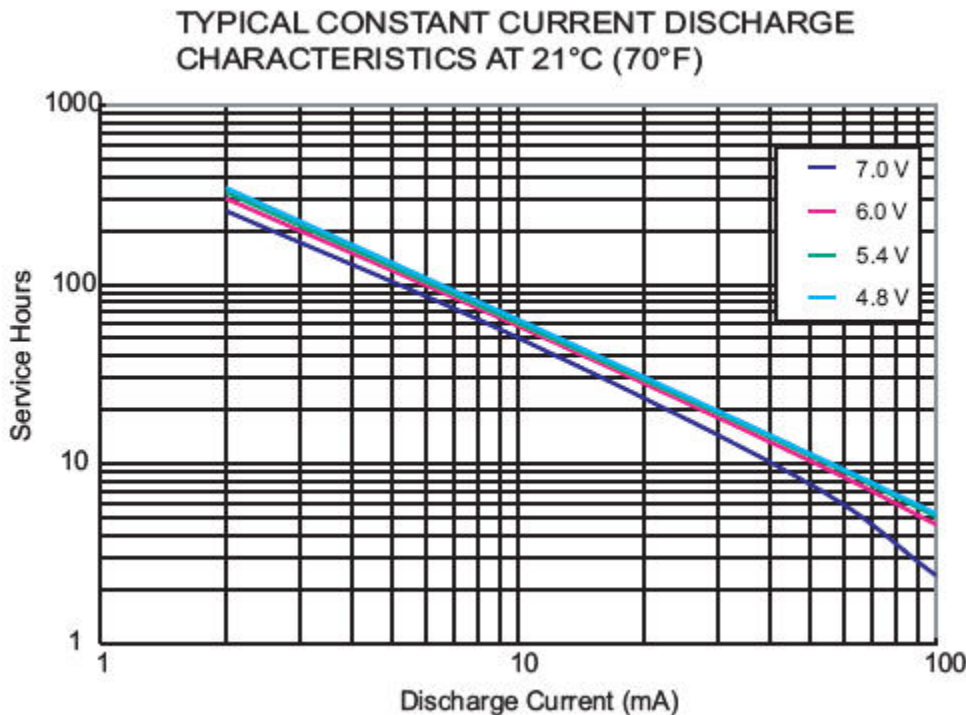

Let's assume that the flight computer draws 100mA of current while operating. (The G-Wiz MC2 draws 100mA while flashing and beeping.) This chart shows that, under these conditions, a typical battery will discharge down to 7 volts in about 2.3 hours. The value is read from the Service Hours axis at the point where the 7.0V line crosses the 100mA line.



# ARLISS-M Design Guide

The 2.3-hour service life is for the typical battery. Some will last longer. Some won't last this long. A battery will also discharge faster at the higher temperatures of the Black Rock Desert. To be safe, this battery powering a 100mA load, should be replaced after 1.5 hours. (I used an arbitrary 35% derating factor to account for increased operating temperature and variation from "typical" life.)

Also note that the charge in a battery is reduced over time, even if it's not connected to anything. When stored at room temperature, the typical alkaline battery loses about 5% of its capability in the first year (3% in subsequent years). Storing batteries at high temperatures will deplete them faster.

NiMH rechargeable batteries will lose about 30% of their charge for each month that they are stored. If you are using rechargeable batteries, they should be recently charged. Deeply discharging a rechargeable battery may permanently damage it. To prevent over discharging, these batteries should be recharged before they use 80% of their calculated ampere-hour capacity. Under good care conditions a NiMH battery can be recharged over 500 times.

Depending on how long your rocket sits armed on the launch pad and how long it takes you to recover it and turn off the computer, a battery may only last one flight. Rechargeable batteries will typically discharge faster than equivalent single use alkaline batteries.

Trick for reading log/log charts:

The previous chart uses logarithmic scales on both axis. The gridlines across the bottom of the chart are read as 1, 2, 3, 4, 5, 6, 7, 8, 9, 10, 20, 30, 40, 50, 60, 70, 80, 90, 100 mA. If the chart continued, the next values would be 200, 300, 400, ... This numbering also applies to the vertical axis.

Note that the #3 grid line is about half way between 1 and 10. Note also that the 7V line crosses the 100 mA line at a Service Hours value half way between 2 and 3. This halfway point corresponds to the value of 2.3 hours.

## **Batteries Powering Pyro Circuits**

The discharge characteristic of a pyro battery is very different. When a flight computer is turned on and waiting for launch, pyro battery power is used to repeatedly test e-match electrical circuit continuity. Then, when a pyro channel fires, a significant amount of current is drawn from the battery for a short period of time.

During continuity testing the average drain on the battery is approximately 2 milliamps. From the above chart, it can be seen that the battery should last over 200 hours in this mode.

During a pyro event an e-match will attempt to draw 9 Amps from the 9V battery. The battery is unable to supply this much current and the internal resistance of the battery will limit its current to about 3 Amps. These batteries are not designed to deliver currents in

# ARLISS-M Design Guide

this range and there is nothing in their specifications to describe their behavior. So data must be obtained by experimentation with a specific brand/model of battery.

The construction of e-matches also varies greatly. When exposed to 9V, some e-matches pop immediately, others last a couple seconds before they burn through. The e-matches that pop immediately seem to have very little drain on the battery's capacity. A single battery has been used over 7 times to ignite e-matches of this type without any measurable decrease in the battery's voltage. When a battery delivers a high current, localized internal heating occurs. Prolonged overheating of this type will damage the battery and could cause it to explode. It is strongly suggested that you test the battery/e-match combination that you are using.

To test your battery/e-match combination:

1. Measure your battery's voltage.
2. Use the battery to ignite an e-match.
3. Allow the battery time to dissipate any heat that was internally generated.
4. Repeat the above steps.

You can either repeat the above steps until you notice that the battery is having trouble igniting the e-match, or you decide that you don't want to burn any more e-matches in the experiment. In either case, use half the number of igniters burnt as your limit.

It is recommended that you do not power your flight computer with the same battery that is used for pyro events. When a large current is drawn from a battery, its voltage temporarily reduced. (The voltage at the terminals of a 9V battery could easily drop to 4V while powering a pyro event.) This voltage drop could well be too low for too long for your flight computer handle. If your flight computer is deprived of power, it will behave as if it was turned off and back on. It will forget that the launch event occurred and probably fail to trigger subsequent pyro events. Memory inside the flight computer may also be corrupted.

## Appendix D. Reference Design Drawings

### Drawings:

1. ARLISS rocket airframe drawing from  
[http://www.arliss.org/resources/arliss\\_booster.pdf](http://www.arliss.org/resources/arliss_booster.pdf)
2. External dimensions of the standard payload carrier.
3. The ARLISS-M aluminum fin from  
[http://www.feretich.com/Rocketry/SuperArliss/specs/FINS\\_arliss.pdf](http://www.feretich.com/Rocketry/SuperArliss/specs/FINS_arliss.pdf)

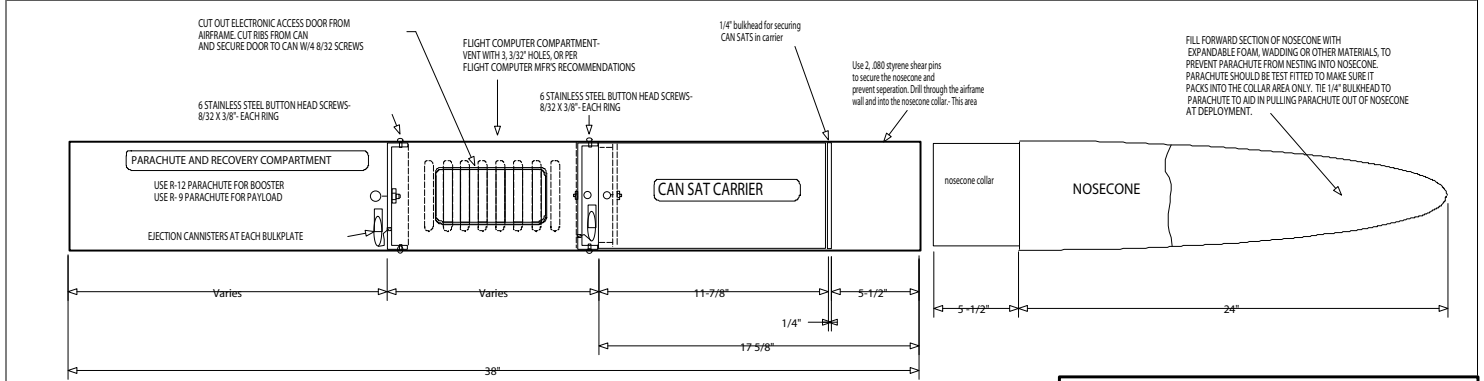
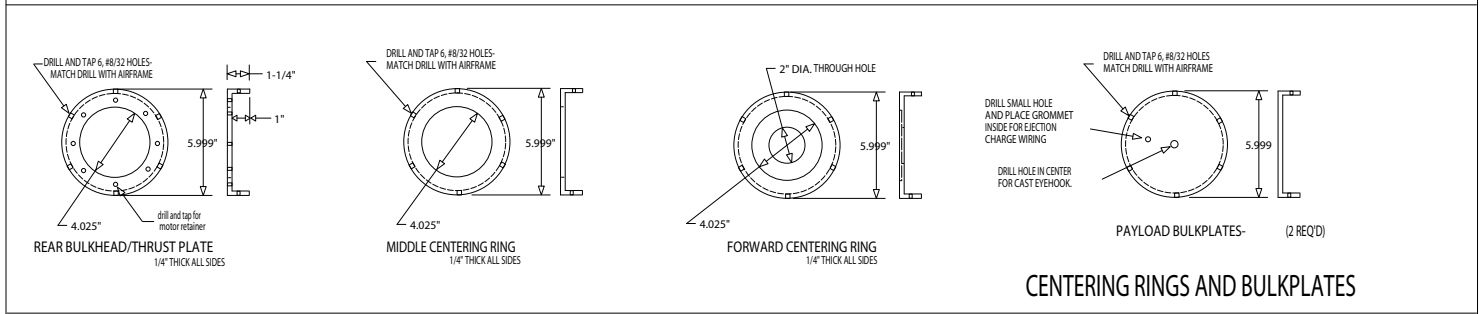
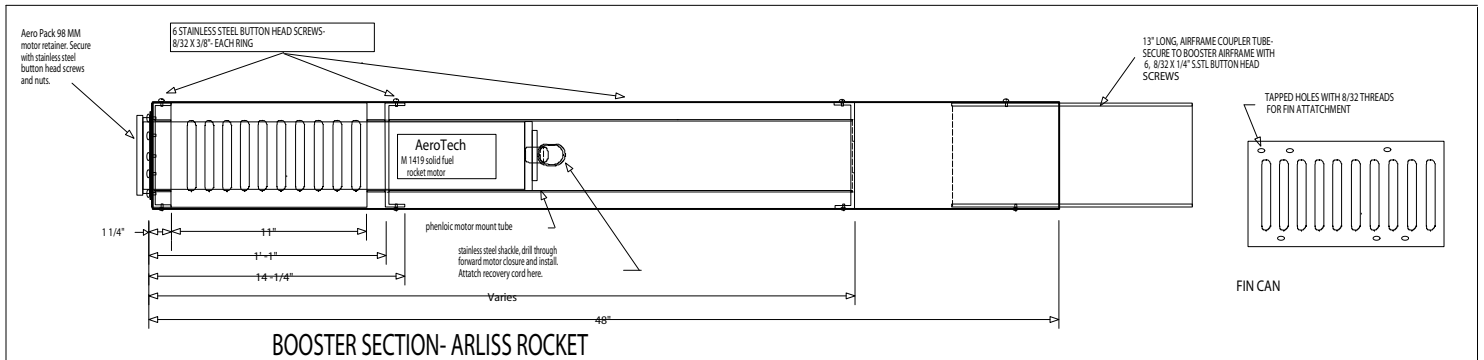

ARLISS 2001 - ROCKET DESIGN		
Design #2- rear ejection	REVISIONS- 1.11.29.000 #12.201	DRAWN BY: TOM ROUSE SCALE: none



REVISIONS

ZONE	REV	DESCRIPTION	DATE	APPROVED
------	-----	-------------	------	----------

# M-Class Payload Carrier External Dimensions

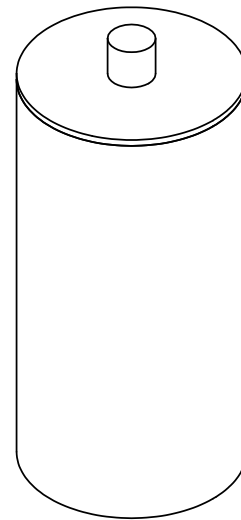
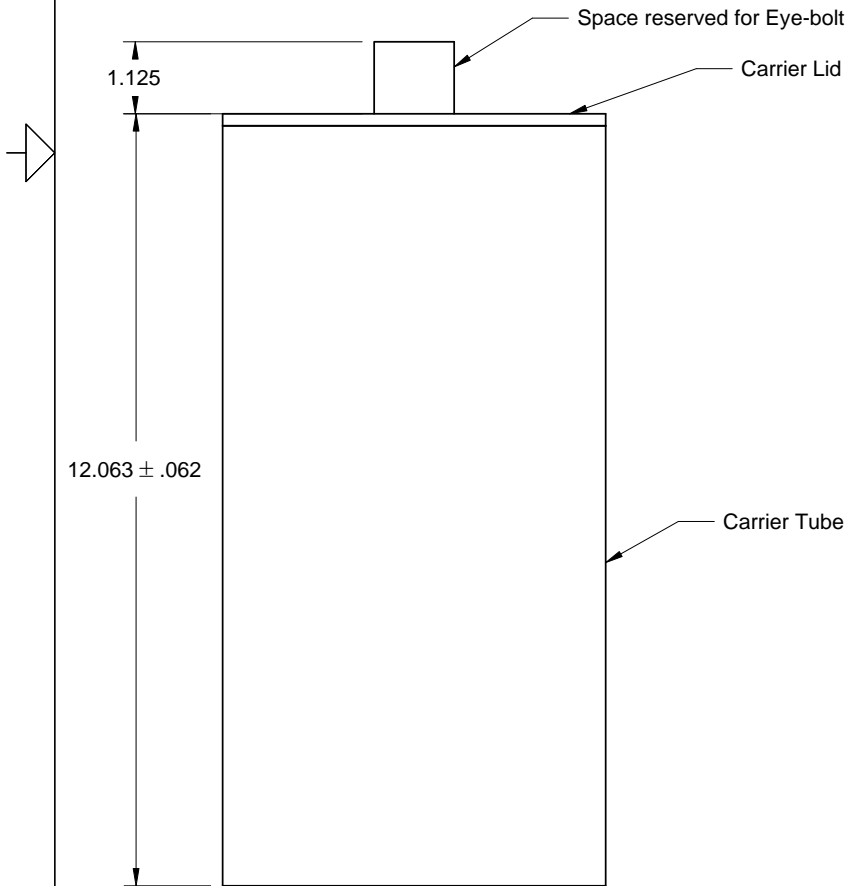
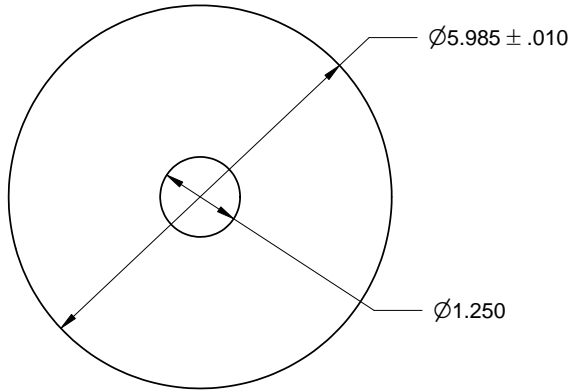

SIZE <b>A</b>	FSCM NO.	DWG NO.	REV
SCALE		B. Feretich	SHEET



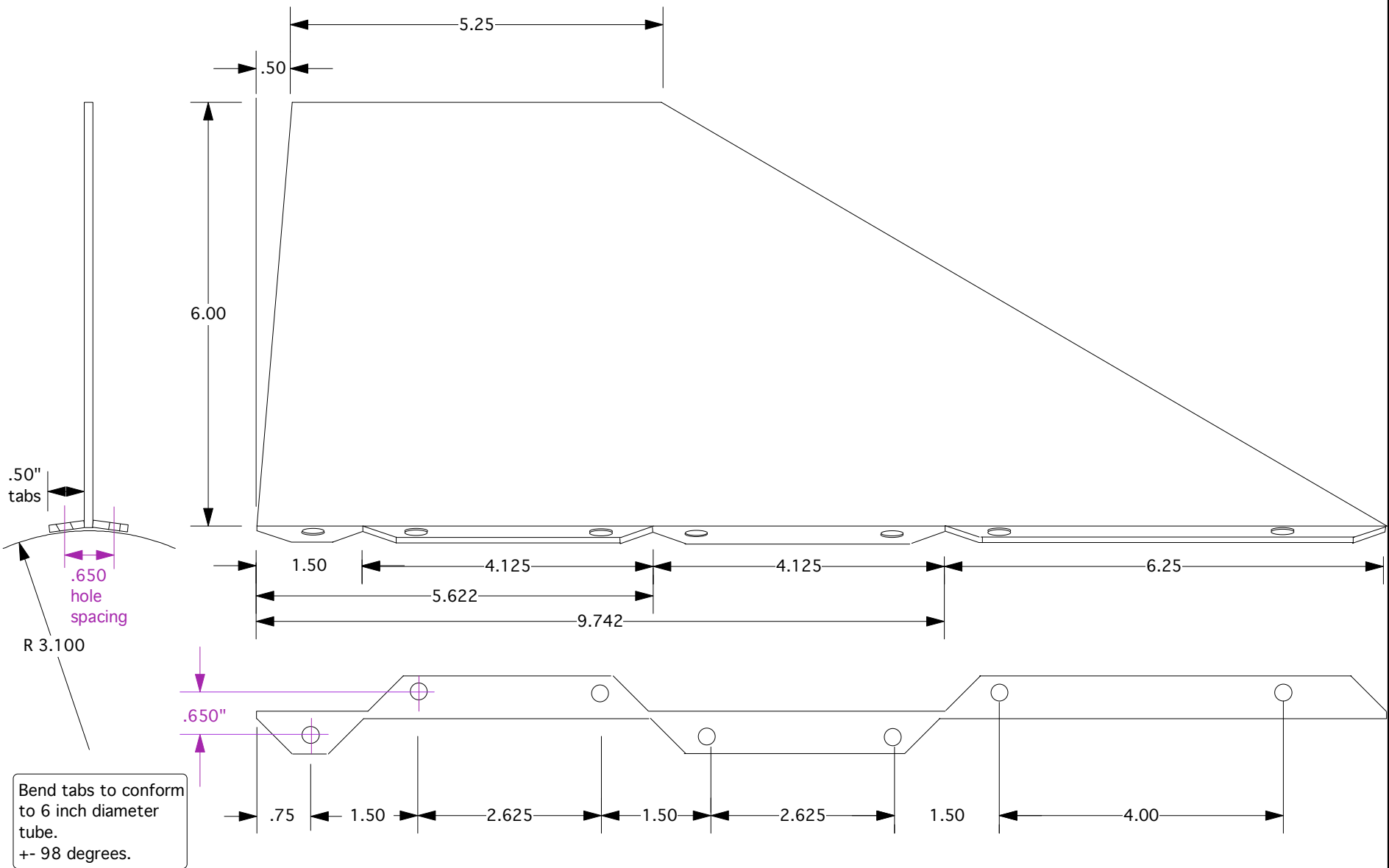

FIN MATERIAL- ALUMINUM.  
 THICKNESS- .090" MINIMUM  
 BRUSHED ALUMINUM, BLACK ANODIZED

ARLISS ROCKET		2/2/2007
FIN DRAWING		DRAWN BY-
		TR